

DRAINAGE & WASTE WATER PUMPS

ST SERIES 415V



CLEARTEC PUMPS

2
YEAR
WARRANTY

T&Cs apply



ST10-14JM / ST10-14JA

Heavy duty submersible drainage & waste water pump ideal for agricultural drainage & irrigation, building storm water /subsoil removal & drainage bilge water.

- Durable cast iron outer casing for superior heat transfer.
- In built auto reset motor protector.
- Side discharge.
- Standard 10 mts power cable.

Mechanical Seal	Double Silicon carbide upper & lower faces
Impeller	Semi-open
Motor Protection	Klixon auto reset
Pump Configuration	Free standing. Guide rail.
Liquid Temp	≤ 40 °C
Voltage	3 Phase 415V

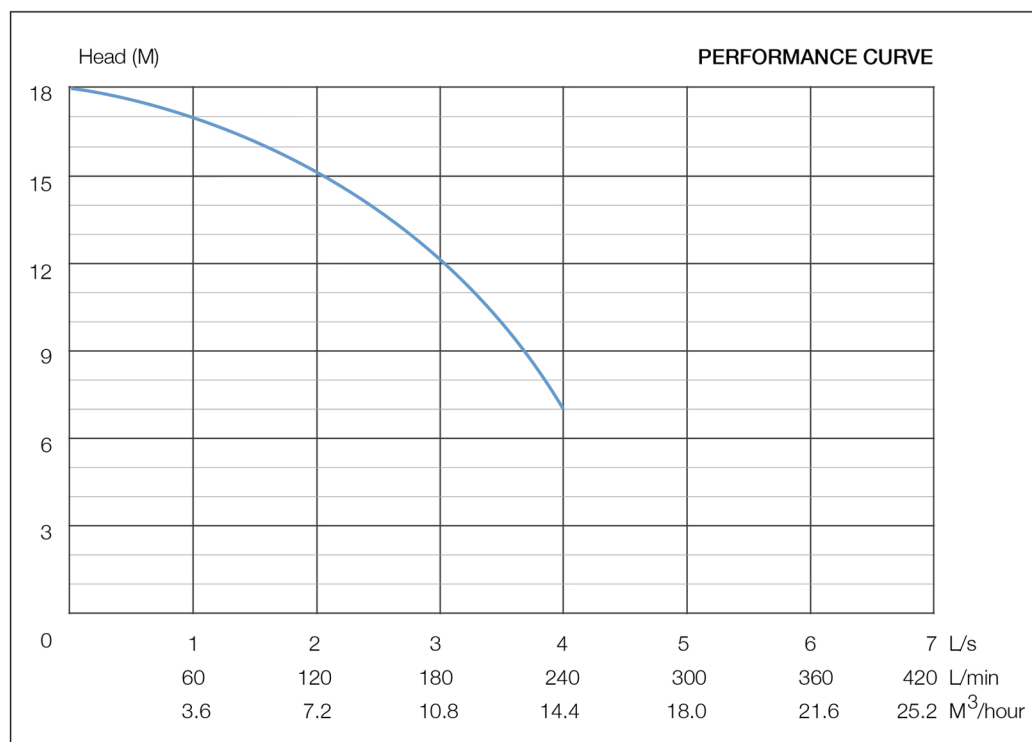

Pump Dimensions

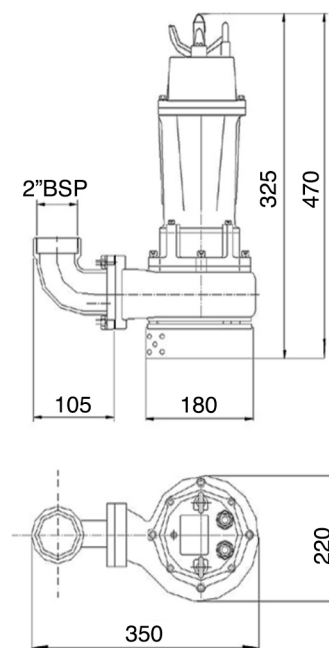

ST10-14 0.75Kw 415V

MODEL NO	Discharge (mm)	Max Flow (L/s)	Max Head (m)	Output (Kw)	Voltage (V)	FLC (A)	RPM	Solid size (mm)	Weight (Kg)	Insulation Class
ST10-14JM	50	4	18	0.75	415	1.7	2900	7	27	B
ST10-14JA	50	4	18	0.75	415	1.7	2900	7	27	B

M (manual) A (automatic) J (semi-open impeller)