

DRAINAGE & WASTE WATER PUMPS

SS SERIES 240V



CLEARTEC PUMPS



T&Cs apply



SS10-24

SS10-24JM / SS10-24JA

Heavy duty submersible drainage & waste water pump ideal for agricultural drainage & irrigation, building storm water /subsoil removal & drainage bilge water.

- Durable cast iron outer casing for superior heat transfer.
- Balanced impeller
- In built auto reset motor protector.
- Side discharge.
- Standard 10 mts power cable.

Mechanical Seal	Double Silicon carbide upper & lower faces
Impeller	Semi Open
Motor Protection	Klixon auto reset
Pump Configuration	Free standing. Guide Rail.
Liquid Temp	≤ 40 °C
Voltage	Single Phase 240V

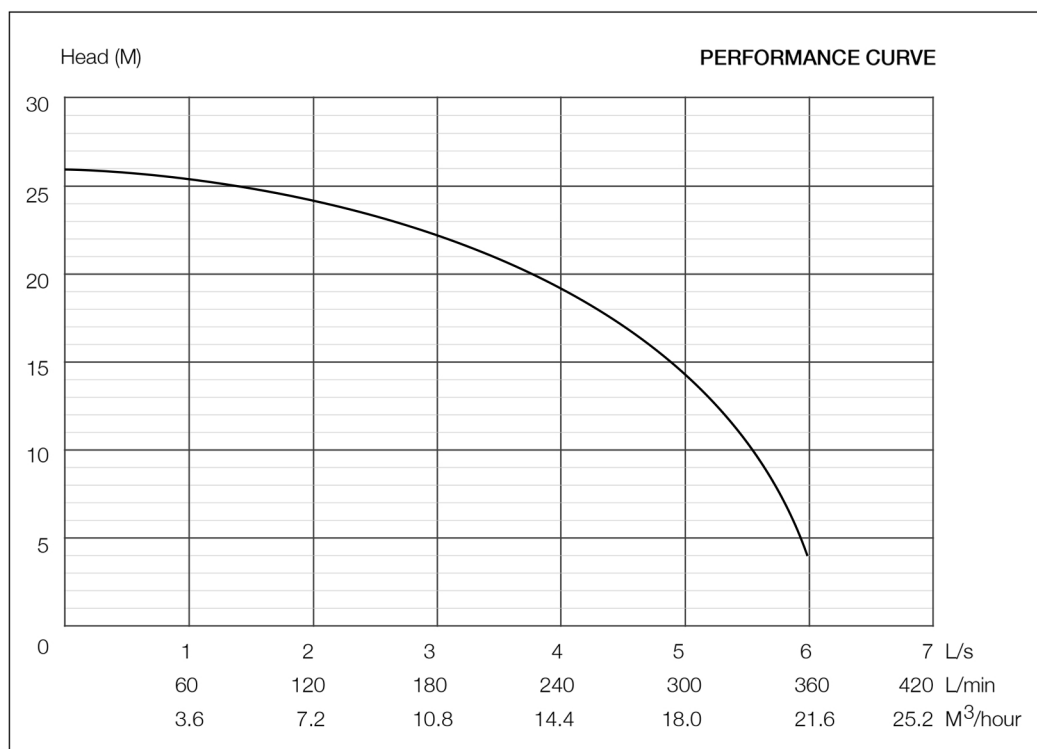

Pump Dimensions

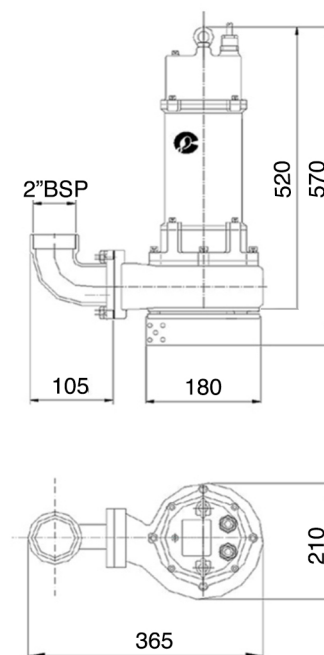

SS10-24 1.5Kw 240V

MODEL NO	Discharge (mm)	Max Flow (L/s)	Max Head (m)	Output (Kw)	Voltage (V)	FLC (A)	RPM	Solid Size (mm)	Weight (Kg)	Insulation Class
SS10-24JM	50	6	26	1.5	240	9.5	2900	7	38	F
SS10-24JA	50	6	26	1.5	240	9.5	2900	7	38	F

M (manual) A (automatic) J (semi-open impeller)

PICTURES ARE FOR ILLUSTRATIVE PURPOSES ONLY
 DISCLAIMER: EVERY EFFORT HAS BEEN MADE TO PUBLISH CORRECT DETAILS.
 NO RESPONSIBILITY WILL BE TAKEN FOR ERRORS OR CHANGES IN PRODUCT SPECIFICATION.
 DATE: 12.11.20