

# CUTTER SEWAGE PUMPS

## CPE SERIES 415V



CLEARTEC PUMPS

**2**  
YEAR  
WARRANTY

T&Cs apply



### CPE400-2LM / CPE400-2LA

CPE Series are durable cast iron pumps designed for raw sewage and industrial wastewater.

- Durable cast iron outer casing for superior heat transfer.
- Hardened steel cutter plate with wear adjustment.
- High torque motor incorporating centrifugal switch.
- Standard 10 mts power cable.

<b>Mechanical Seal</b>	Double Silicon carbide upper & lower faces
<b>Impeller</b>	Cutter single vane with tungsten carbide cutting tip
<b>Motor Protection</b>	Klixon auto reset
<b>Pump Configuration</b>	Free standing. Guide rail.
<b>Liquid Temp</b>	≤ 40 °C
<b>Voltage</b>	3 Phase 415V

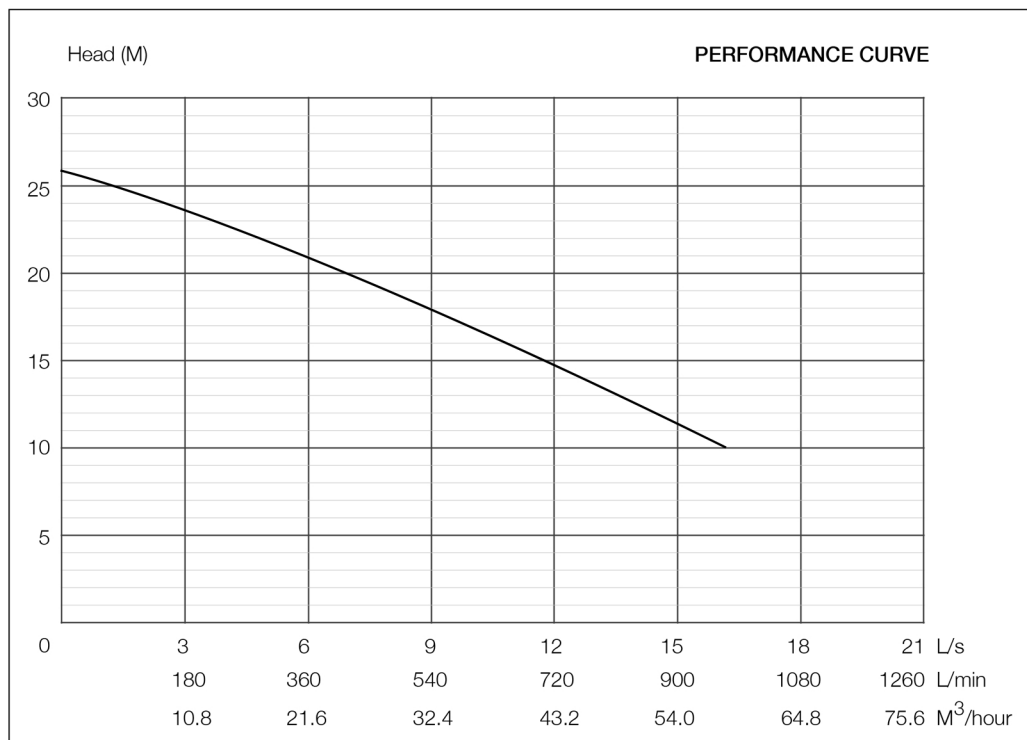

### Pump Dimensions

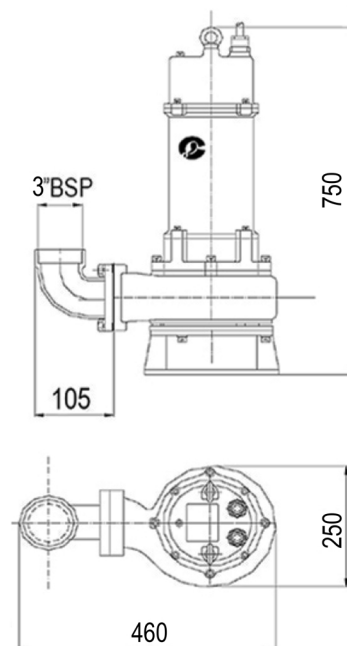

### CPE400-2L 4.0Kw 415V

MODEL NO	Discharge (mm)	Max Flow (L/s)	Max Head (m)	Output (Kw)	Voltage (V)	FLC (A)	RPM	Weight (Kg)	Insulation Class
<b>CPE400-2LM</b>	80	16.5	26	4.0	415	8.5	2900	85	F

M (manual)      L (low head)