

CUTTER SEWAGE PUMPS CPE SERIES 415V



CLEARTEC PUMPS

2
YEAR
WARRANTY

T&Cs apply



CPE400-2HM / CPE400-2HA

CPE Series are durable cast iron pumps designed for raw sewage and industrial wastewater.

- Durable cast iron outer casing for superior heat transfer.
- Hardened steel cutter plate with wear adjustment.
- High torque motor incorporating centrifugal switch.
- Standard 10 mts power cable.

Mechanical Seal	Double Silicon carbide upper & lower faces
Impeller	Cutter single vane with tungsten carbide cutting tip
Motor Protection	Klixon auto reset
Pump Configuration	Free standing. Guide rail.
Liquid Temp	≤ 40 °C
Voltage	3 Phase 415V

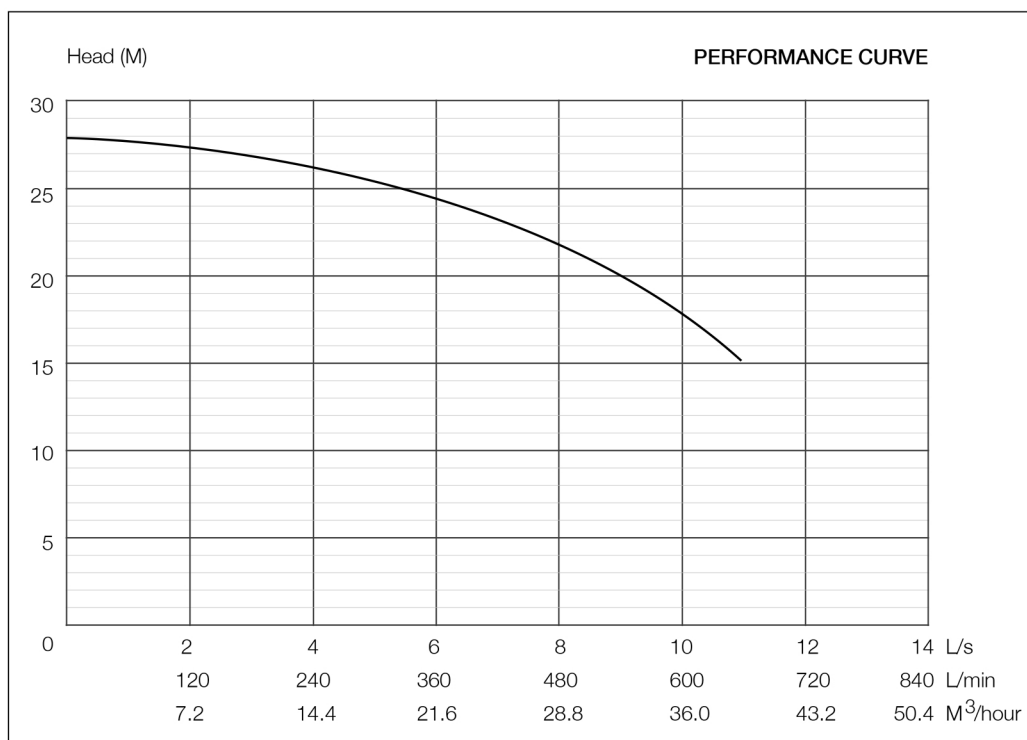

Pump Dimensions

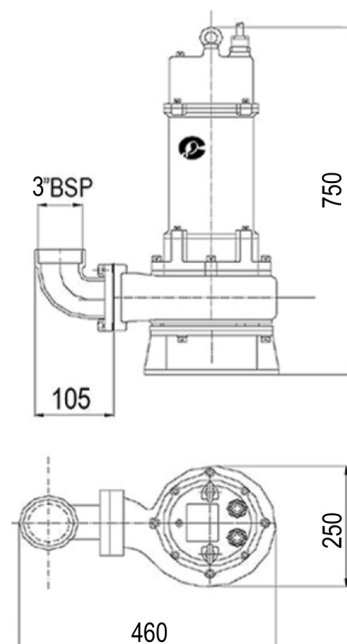

CPE400-2H 4.0Kw 415V

MODEL NO	Discharge (mm)	Max Flow (L/s)	Max Head (m)	Output (Kw)	Voltage (V)	FLC (A)	RPM	Weight (Kg)	Insulation Class
CPE400-2HM	80	11	28	4.0	415	8.5	2900	85	F

M (manual) H (high head)