

CUTTER SEWAGE PUMPS CPE SERIES 415V



CLEARTEC PUMPS

2
YEAR
WARRANTY

T&Cs apply



CPE300-2H

CPE300-2HM / CPE300-2HA

CPE Series are durable cast iron pumps designed for raw sewage and industrial wastewater.

- Durable cast iron outer casing for superior heat transfer.
- Hardened steel cutter plate with wear adjustment.
- High torque motor incorporating centrifugal switch.
- Standard 10 mts power cable.

Mechanical Seal	Double Silicon carbide upper & lower faces
Impeller	Cutter single vane with tungsten carbide cutting tip
Motor Protection	Klixon auto reset
Pump Configuration	Free standing. Guide rail.
Liquid Temp	≤ 40 °C
Voltage	3 Phase 415V

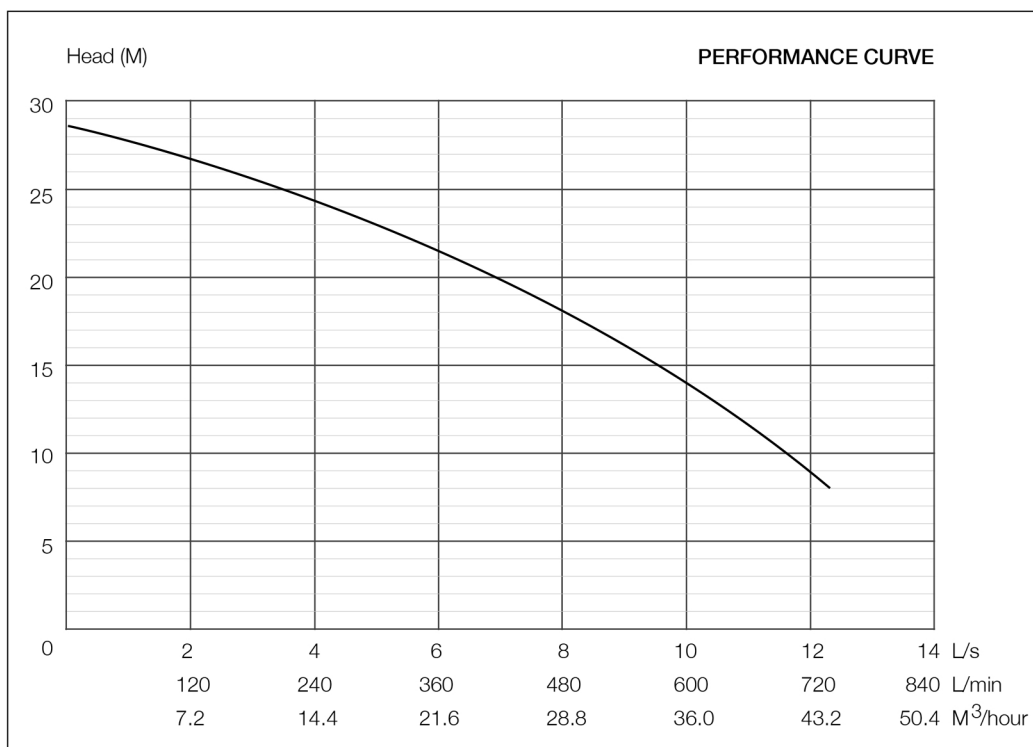

Pump Dimensions

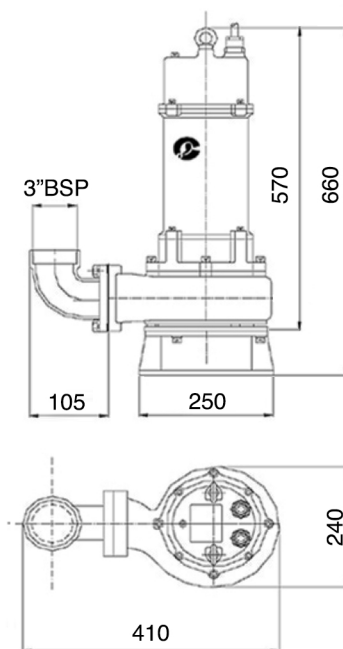

CPE300-2H 3.0Kw 415V

MODEL NO	Discharge (mm)	Max Flow (L/s)	Max Head (m)	Output (Kw)	Voltage (V)	FLC (A)	RPM	Solid Size (mm)	Weight (Kg)	Insulation Class
CPE300-2HM	80	12.5	28.5	3.0	415	6.4	2900	50	54	F
CPE300-2HA	80	12.5	28.5	3.0	415	6.4	2900	50	54	F

M (manual) A (automatic) H (high head)

PICTURES ARE FOR ILLUSTRATIVE PURPOSES ONLY
DISCLAIMER: EVERY EFFORT HAS BEEN MADE TO PUBLISH CORRECT DETAILS
NO RESPONSIBILITY WILL BE TAKEN FOR ERRORS OR CHANGES IN PRODUCT SPECIFICATION.
DATE: 12.11.20