

DRAINAGE & WASTE WATER PUMPS

SS SERIES 240V



CLEARTEC PUMPS

2
YEAR
WARRANTY

T&C's apply



SS25-6

SS25-6M / SS25-6A

Heavy duty submersible drainage & waste water pump ideal for agricultural drainage & irrigation, building storm water /subsoil removal & drainage bilge water.

- Durable cast iron outer casing for superior heat transfer.
- Balanced impeller
- In built auto reset motor protector.
- Side discharge.
- Standard 10 mts power cable.

Mechanical Seal	Double Silicon carbide upper & lower faces
Impeller	Enclosed Channel
Motor Protection	Klixon auto reset
Pump Configuration	Free standing. Guide Rail.
Liquid Temp	≤ 40 °C
Voltage	Single Phase 240V

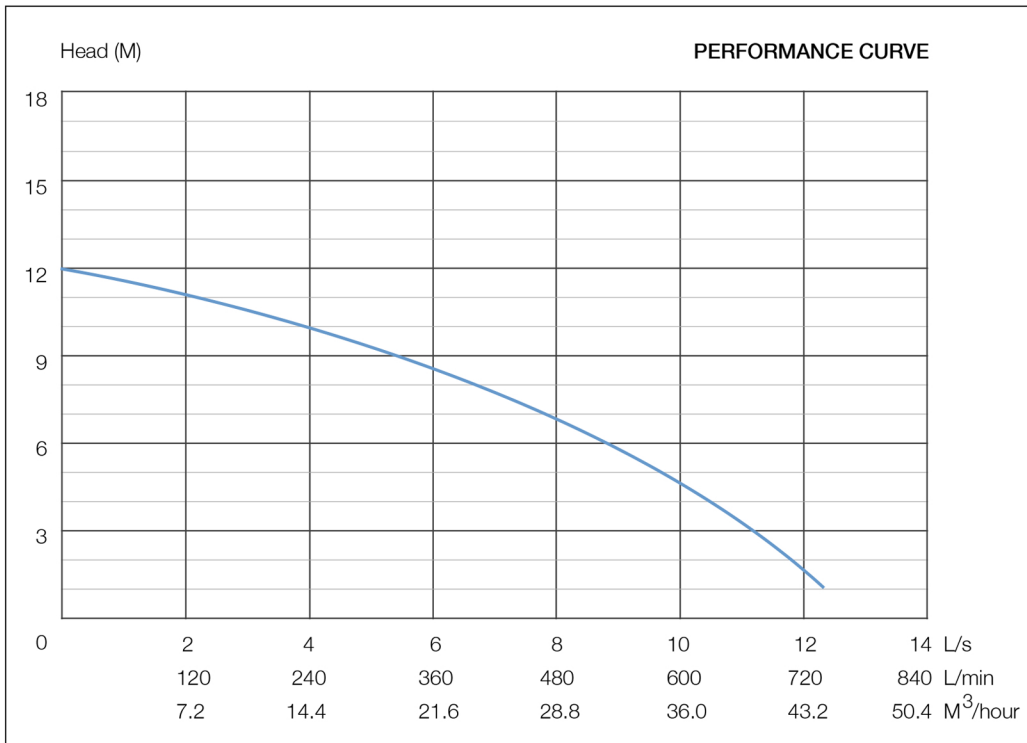

Pump Dimensions

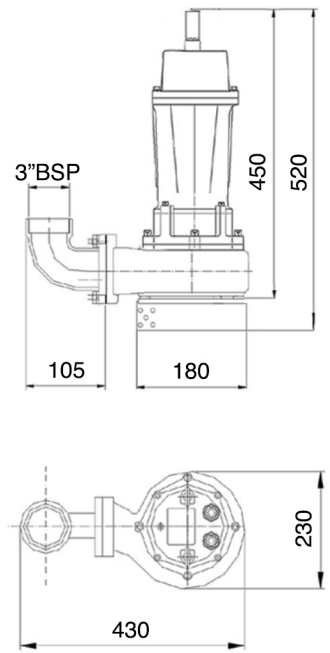

SS25-6 0.75Kw 240V

MODEL NO	Discharge (mm)	Max Flow (L/s)	Max Head (m)	Output (Kw)	Voltage (V)	FLC (A)	RPM	Solid Size (mm)	Weight (Kg)	Insulation Class
SS25-6M	80	12.5	12	0.75	240	6.4	2900	14	35	B
SS25-6A	80	12.5	12	0.75	240	6.4	2900	14	35	B

M (manual) A (automatic)

*Comes standard with strainer

PICTURES ARE FOR ILLUSTRATIVE PURPOSES ONLY.
DISCLAIMER: EVERY EFFORT HAS BEEN MADE TO PUBLISH CORRECT DETAILS.
NO RESPONSIBILITY WILL BE TAKEN FOR ERRORS OR CHANGES IN PRODUCT SPECIFICATION.

DATE: 12.11.20