

GRINDER SEWAGE PUMPS

MPE SERIES 415V



CLEARTEC PUMPS



2
YEAR
WARRANTY

T&Cs apply

MPE400-2L



MPE400-2LM

MPE Series pumps are compatible for raw sewage and industrial wastewater. Equipped with grinder mechanism made of high chrome steel, it efficiently grinds up materials suspended in fluid such as plastics and textiles.

- High chrome steel grinder.
- Standard 10mts cable.

Mechanical Seal	Double Silicon carbide upper & lower faces
Impeller	Grinder- High Chrome Steel
Motor Protection	Klixon auto reset
Pump Configuration	Free standing. Guide rail.
Liquid Temp	≤ 40 °C
Voltage	3 Phase 415V

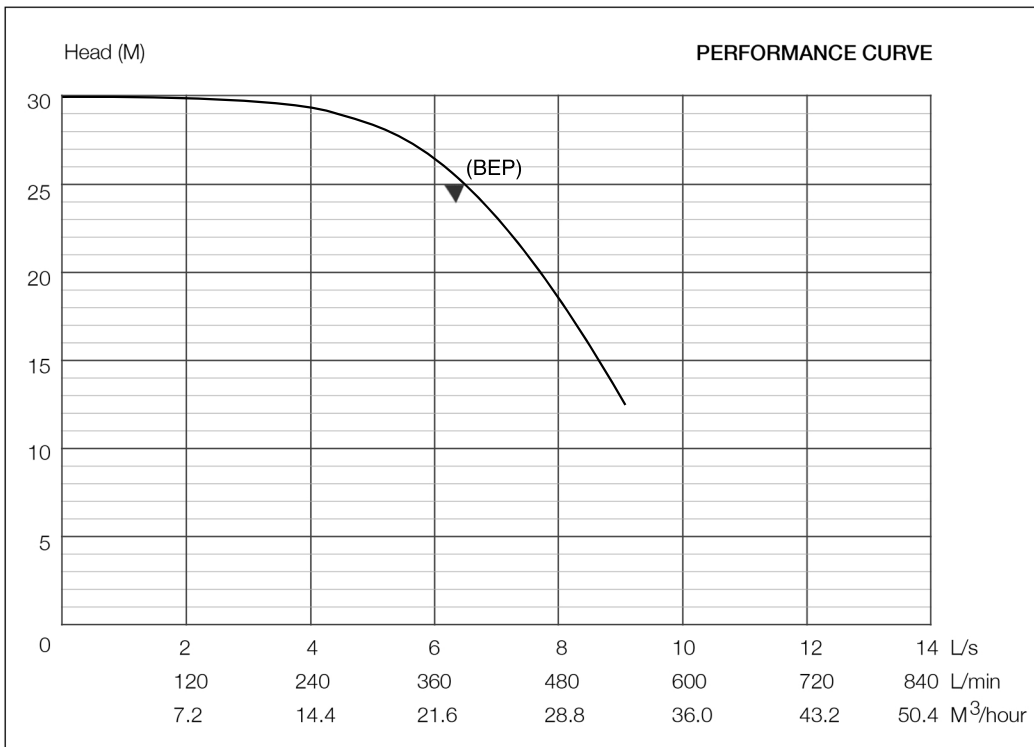

Pump Dimensions

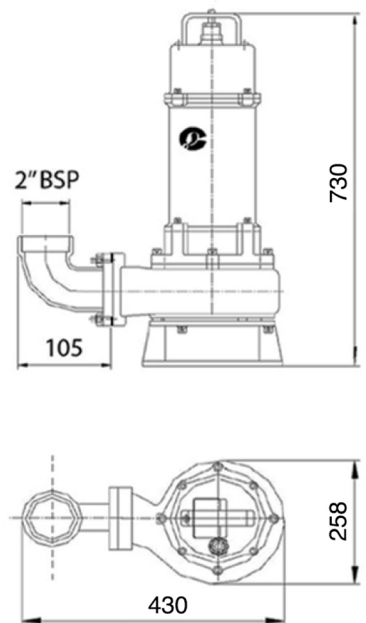

MPE400-2L 4.0Kw 415V

MODEL NO	Discharge (mm)	Max Flow (L/s)	Max Head (m)	Output (Kw)	Voltage (V)	FLC (A)	BEP L / M	RPM	Weight (Kg)	Insulation Class
MPE400-2LM	50	9	30	4.0	415	8.5	6.5 / 25	2900	100	F

M (manual) L (low head)