

CUTTER SEWAGE PUMPS

CPE SERIES 415V



CLEARTEC PUMPS

2
YEAR
WARRANTY

T&Cs Apply



CPE80-2M / CPE80-2A

CPE Series are durable cast iron pumps designed for raw sewage and industrial wastewater.

- Durable cast iron outer casing for superior heat transfer.
- Hardened steel cutter plate with wear adjustment.
- High torque motor incorporating centrifugal switch.
- Standard 10 mts power cable.

Mechanical Seal	Double Silicon carbide upper & lower faces
Impeller	Cutter single vane with tungsten carbide cutting tip
Motor Protection	Klixon auto reset
Pump Configuration	Free standing. Guide rail.
Liquid Temp	≤ 40 °C
Voltage	3 Phase 415V

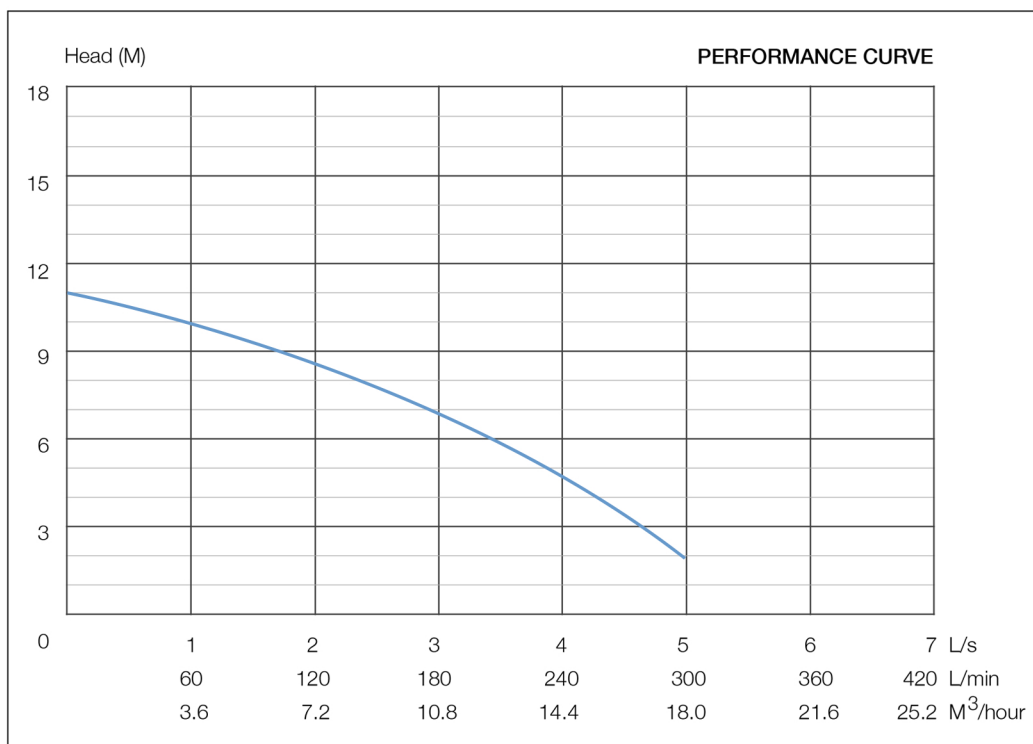

Pump Dimensions

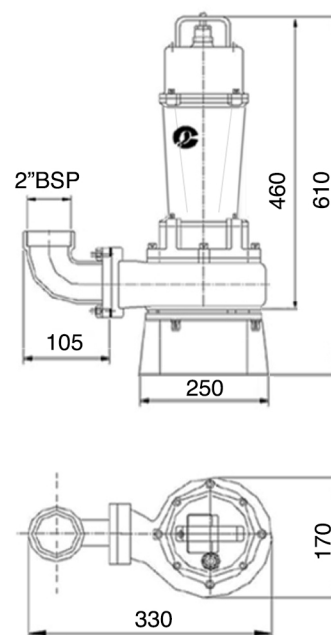

CPE80-2 0.75Kw 415V

MODEL NO	Discharge (mm)	Max Flow (L/s)	Max Head (m)	Output (Kw)	Voltage (V)	FLC (A)	RPM	Solid size (mm)	Weight (Kg)	Insulation Class
CPE80-2M	50	5	11	0.75	415	1.7	2900	50	35	B
CPE80-2A	50	5	11	0.75	415	1.7	2900	50	35	B

M (manual) A (automatic)

* Comes fitted with standard base as shown, or can be fitted with low base on request.